

Technical specifications

- Flow rate: 10 ÷ 120 l/h
- Max pressure: 5 bar
- Motor:
 - 0.06 kW - 3ph (IP55)
 - 0.06 kW - 1ph (IP55)
- Stroke rate: from 26 to 144 stroke /minute
- Stroke length: 4.2 - 5 - 6.8 mm
- Diaphragm diameter: 70mm
- Pump head:
 - SS 316
 - PVDF
- Max temperature:
 - SS 316 90° C
 - PVDF 40° C

MSV Series is a new motor driven mechanical diaphragm metering pump featuring a vertically mounted, high efficiency, high performing motor, within a PVC housing. Enhanced by its dual cam mechanical structure, the pump features high levels of stability whilst remaining a low noise unit and offering a very precise flow rate.

Suitable for a wide range of uses, it offers a high level of repetitive accuracy and is capable of pumping a wide range of viscous liquids, slurries or chemicals.

The MSV series electric motor drives pump mechanism's plunger backwards and forwards, drawing the membrane and creating suction from the supply chamber. The resulting volume change in the pump chamber in turn pushes the ball up and generates a squeezing action to effect fluid transfer.

The flow rate of between 10÷120 l/h can be adjusted by regulating the stroke length.

MSV Pump offers the following key features designed to ensure efficient, long term reliable pumping and fluid transfer:

- Reduced Footprint – to make installation easier
- Robust plastic outer case – ensures ease of installation and durability
- Simple but robust construction – provide ideal value for money
- High efficiency motor 0.06 kw with high flow rate 10÷120 l/h

PUMP KEY CODE

Field 1	Field 2	Field 3	Field 4	Field 5	Field 6	Field 7	Field 8	Field 9	Field 10
M	SV	F	094	R	41	XT	0	0	0

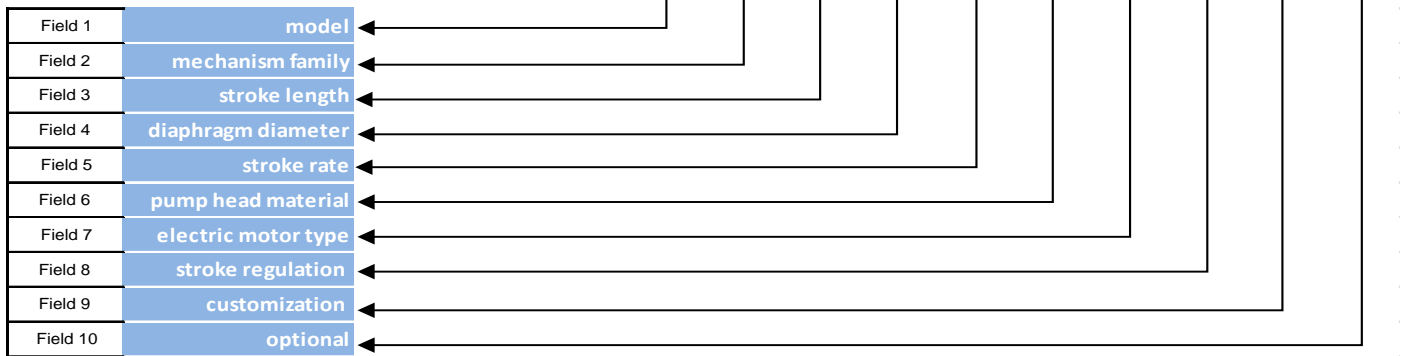

Field 1	model	M	Diaphragm
---------	-------	---	-----------

Field 2	mechanism family	SV	Membrane
---------	------------------	----	----------

Field 3	stroke length	[mm]
	I	4,2
	F	5
	H	6,8

Field 4	diaphragm diameter	[mm]
	070	70

Field 5	stroke rate	stroke/1'
	M	130
	N	86
	O	43
	P	26
	R	144

Field 6	pump head material	head	diaphragm	O-Ring
	21			FPM
	24	SS316		EPDM
	41		PTFE	FPM
	44	PVDF		EPDM

Field 7	electric motor type	
	XT	0,06 kW (4 poles - 3phases - 380 Vac - 50 Hz)
	XD	0,06 kW (4 poles - 1phase - 220 Vac - 50 Hz)

Field 8	optional	
	0	standard

Field 9	customization	
	0	Standard

Field 10	optional	
	0	Standard

HYDRAULIC CHARACTERISTICS

Pump Model	Diaphragm Diameter [mm]	Stroke/min	Flow rate		Max back pressure		Suction/Discharge Connection		Electric Motor 3ph – 380 Vac 1ph – 220 Vac
					bar	p.s.i.			
			l/h	gl/h	SS 316 / PVDF	SS 316 / PVDF	SS 316	PVDF	
M S V I 0 7 0 P	70	26	10	23.78	5	72.52	1/2" g/f	8 x 12	0.06 kW – 4 poles
M S V I 0 7 0 O		43	20	23.78	5	72.52			
M S V I 0 7 0 N		86	40	23.78	5	72.52			
M S V I 0 7 0 M		130	60	23.78	5	72.52			
M S V F 0 7 0 R		144	90	23.78	5	72.52			
M S V H 0 7 0 R		144	120	31.7	3	43.51			

DIMENSIONS

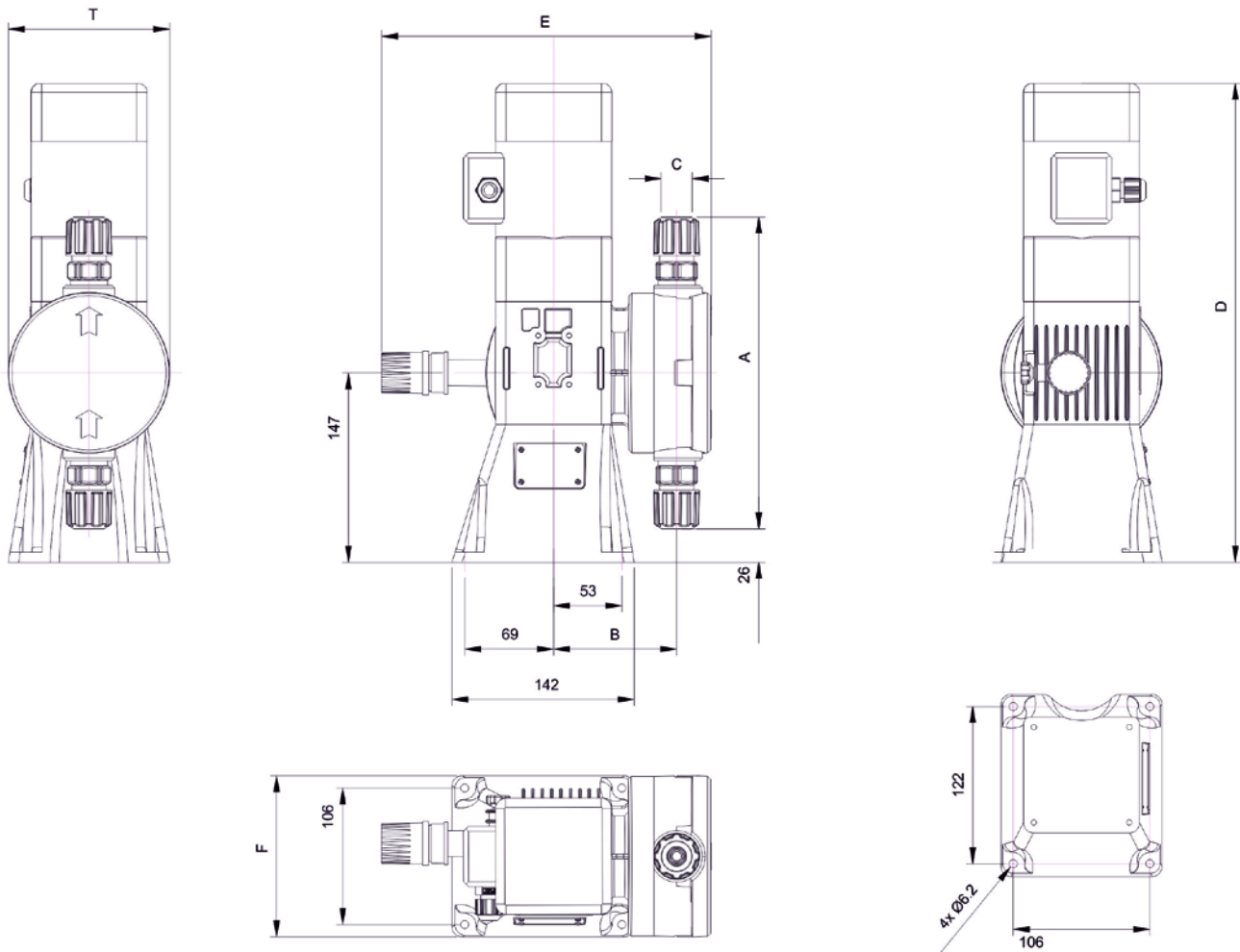

							Single / Three Phases motor	
A [mm]	B [mm]	C [BSP / mm]		T [mm]	D [mm]	E [mm]	F [mm]	
242	93.5	AISI 316	1/2" g/f	372	372	256	125	
		PVDF	8 x 12 (std)					

